

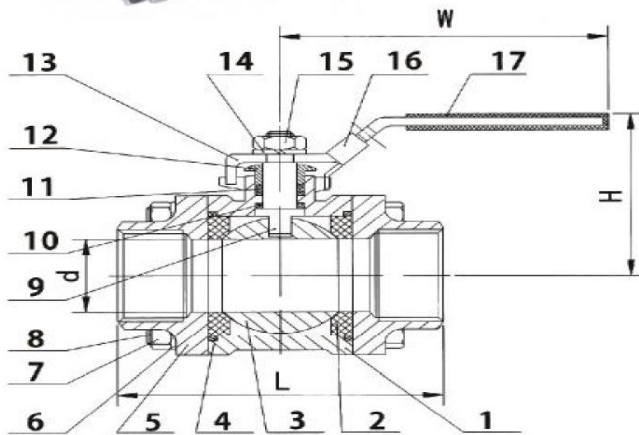

3-PC BALL VALVE



Global Consulting Inc.
"Managing Projects to Success"



DIMENSION LIST

SIZE	d	L	H	W	N • m	Kgs
1/4"	11	47	51	105	4	0.35
3/8"	12.5	47	51	105	4	0.34
1/2"	15	54	53	118	5	0.39
3/4"	20	73	60	118	8	0.73
1"	25	79	75	150	10	1.10
1 1/4"	35	90	80	150	14	1.60
1 1/2"	40	102	88	182	18	2.52
2"	50	118	95	182	25	3.32
2-1/2"	65	149	121	254	48	6.50
3"	80	180	135	254	75	11.00
4"	100	223	158	285	110	19.20

KSPM-31

3-pc Ball Valve

- Investment casting for body and cap
- Full bore
- Threaded ends ANSI B2 1, BS 21, DIN 259/2999
- Pressure rating 1000 PSI (PN63)
- Working temperature -25°C + 180°C
- Material CF8M, CF8, CF3M, WCB

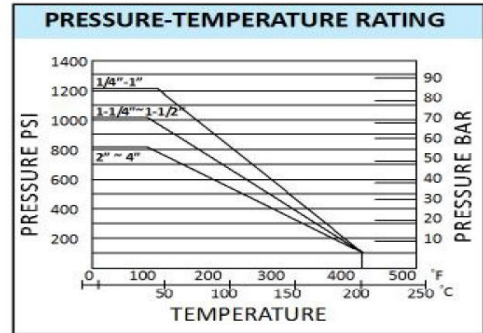

MATERIAL LIST

ITEM	PART	MATERIAL	QTY
1	Body	CF8M	1
2	Ball Seat	R-PTFE(15%)	2
3	Ball	SS316	1
4	Body Gasket	PTFE	2
5	Cap	CF8M	2
6	Spring Washer	SS316	4(12)
7	Nut	SS304	4(12)
8	Bolt	SS304	4(6)
9	Stem	SS304	1
10	Thrust Washer	PTFE	1
11	Stem Packing	PTFE	1
12	Gland Nut	SS304	1
13	Handle	SS304	1
14	Spring Washer	SS304	1
15	Nut	SS304	1
16	Lock Device	SS304	1
17	Handle Cover	Plastic	1



Kspm Global Consulting Inc.

Head Office:

1113 Kestell Blvd., Oakville, Ontario L6H 7M6 Canada.

Website: www.kspmglobal.ca

E-mail: Operations@kspmglobal.ca